



# Compressed Air Treatment

**Compressed air treatment diagrams for rotary screw compressors**  
The perfect treatment components for every application

# Installation recommendations for pure compressed air

Compressed air treatment using a refrigeration dryer (Pressure dew point to +3 °C)

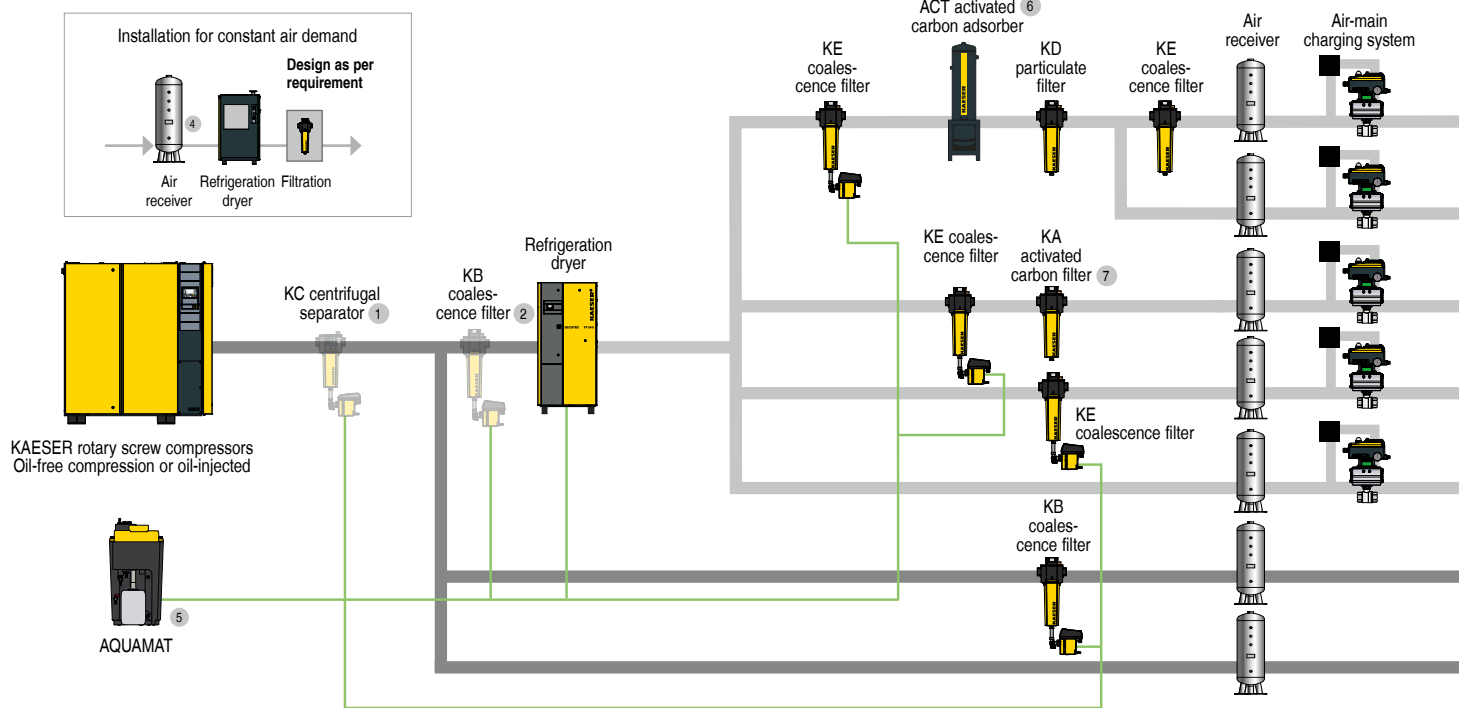

Compressed air treatment with a desiccant dryer (Pressure dew point to -70 °C, e.g. for applications subject to sub-zero temperatures)

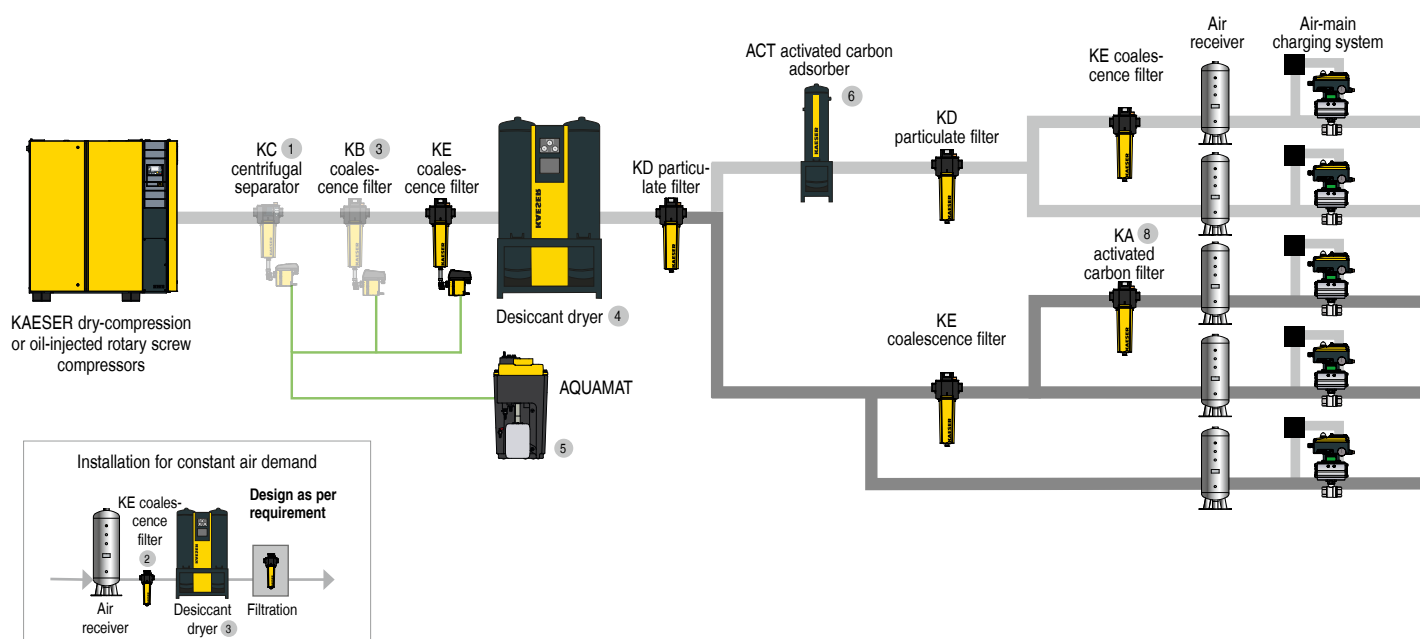

- ① No KC in compressors with integrated centrifugal separators
- ② KB filter installed upstream for third-party compressors or contaminated / highly corroded pipework
- ③ KB filter installed upstream for critical applications requiring high purity compressed air
- ④ KB filter installed upstream for third-party compressors or contaminated / highly corroded pipework
- ⑤ With oil-free compression rotary screw compressors, condensate must be disposed of onsite

**Choose the required grade of treatment according to your field of application:**  
 Application examples: Selection of compressed air treatment classes to ISO 8573-1 (2010)

**Achievable compressed air purity classification**

**Sector/Application**

Particulates	Water	Oil
1	4	1
2	4	1
1	4	1
1	4	2
4	4	3
4	7-X <sup>9</sup>	3
6	7-X <sup>9</sup>	4

Pure air and clean-room technology, dairies, breweries, food production
Especially clean conveying air, chemical plants
Weaving machines, photo labs, pharmaceutical industry
Paint spraying, powder coating, packing, control and instrument air
General works air, high-grade sand blasting
Shot blasting
Conveying air for wastewater systems

**Achievable compressed air purity classification**

**Sector/Application**

Particulates	Water	Oil
1	1-3	1
2	1-3	1
1	1-3	1
1	1-3	2
2	1-3	2

Pure air and clean room technology, pharmaceutical industry, food production
Paint spraying installations
Process air, pharmaceuticals
Photo labs
Especially dry conveying air, paint spraying, fine pressure controllers

**Compressed air quality classification as per ISO 8573-1 (2010):**

Particulates			
Class	Max. particulate count per m <sup>3</sup> of a particle size d [µm] *)		
	0.1 < d ≤ 0.5	0.5 < d ≤ 1.0	1.0 < d ≤ 5.0
0	e.g. Consult KAESER regarding pure air and clean-room technology		
1	≤ 20,000	≤ 400	≤ 10
2	≤ 400,000	≤ 6,000	≤ 100
3	Not defined	≤ 90,000	≤ 1,000
4	Not defined	Not defined	≤ 10,000
5	Not defined	Not defined	≤ 100,000
Class	Particulate concentration C <sub>p</sub> in mg/m <sup>3</sup> *)		
6	0 < C <sub>p</sub> ≤ 5		
7	5 < C <sub>p</sub> ≤ 10		
X	C <sub>p</sub> > 10		

Water	
Class	Pressure dew point, in °C
0	e.g. Consult KAESER regarding pure air and clean-room technology
1	≤ -70 °C
2	≤ -40 °C
3	≤ -20 °C
4	≤ +3 °C
5	≤ +7 °C
6	≤ +10 °C
Class	Concentration of liquid water C <sub>w</sub> in g/m <sup>3</sup> *)
7	C <sub>w</sub> ≤ 0.5
8	0.5 < C <sub>w</sub> ≤ 5
9	5 < C <sub>w</sub> ≤ 10
X	C <sub>w</sub> > 10

Oil	
Class	Total oil concentration (liquid, aerosol + gaseous) [mg/m <sup>3</sup> ] *)
0	e.g. Consult KAESER regarding pure air and clean-room technology
1	≤ 0.01
2	≤ 0.1
3	≤ 1.0
4	≤ 5.0
X	> 5.0

\*) At reference conditions 20 °C, 1 bar(a), 0% humidity.

- ⑥ Service life approx. 12,000 h
- ⑦ Service life approx. 500 h
- ⑧ Service life approx. 1,000 h
- ⑨ Dependent on cooling temperature

# The world is our home

As one of the world's largest compressed air system providers and compressor manufacturers, KAESER KOMPRESSOREN is represented throughout the world by a comprehensive network of branches, subsidiary companies and authorised partners in over 100 countries.

With innovative products and services, KAESER KOMPRESSOREN's experienced consultants and engineers help customers to enhance their competitive edge by working in close partnership to develop progressive system concepts that continuously push the boundaries of performance and compressed air efficiency.

Moreover, the decades of knowledge and expertise from this industry-leading system provider are made available to each and every customer via the KAESER group's global computer network.

These advantages, coupled with KAESER's worldwide service organisation, ensure that every product operates at the peak of its performance at all times and provides maximum availability.



## KAESER KOMPRESSOREN SE

P.O. Box 2143 – 96410 Coburg – GERMANY – Tel +49 9561 640-0 – Fax +49 9561 640-130  
e-mail: [productinfo@kaeser.com](mailto:productinfo@kaeser.com) – [www.kaeser.com](http://www.kaeser.com)